

Рис. 1.1



Рис. 2.1а



Рис. 2.1б

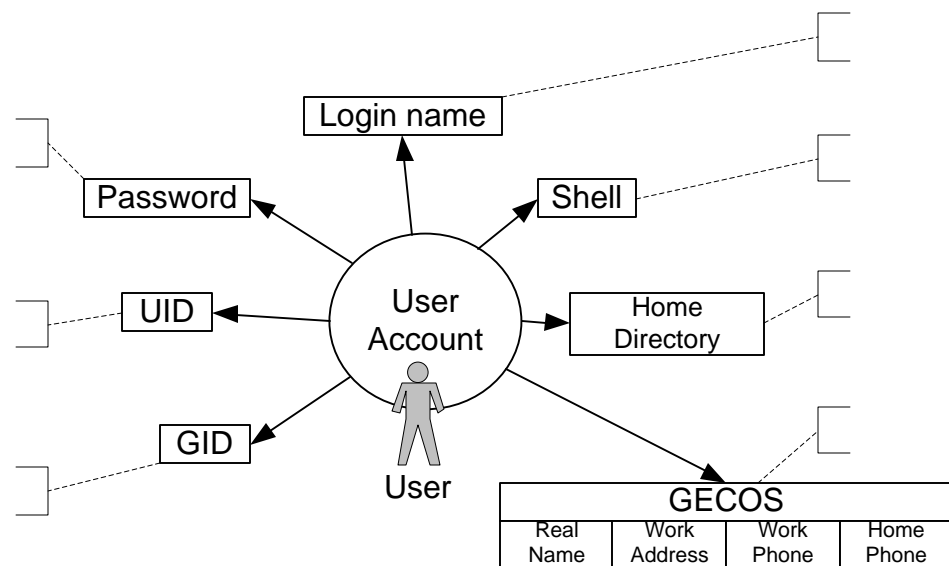

Рис. 3.1

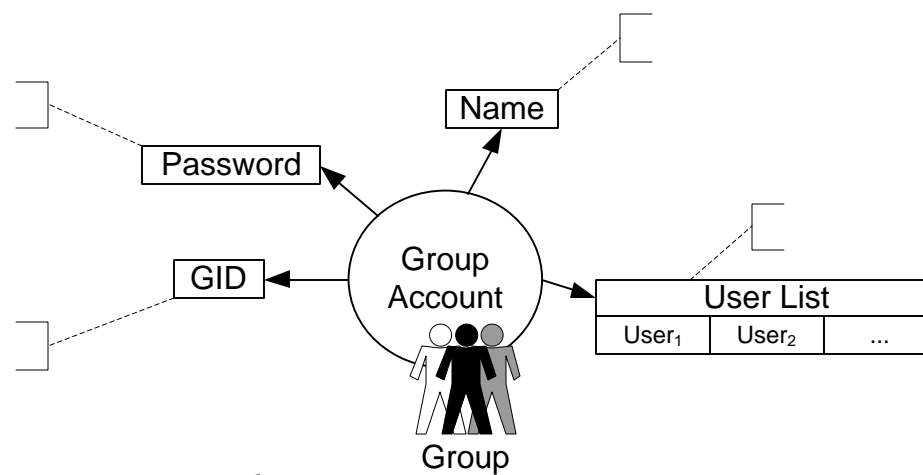

Рис. 3.2

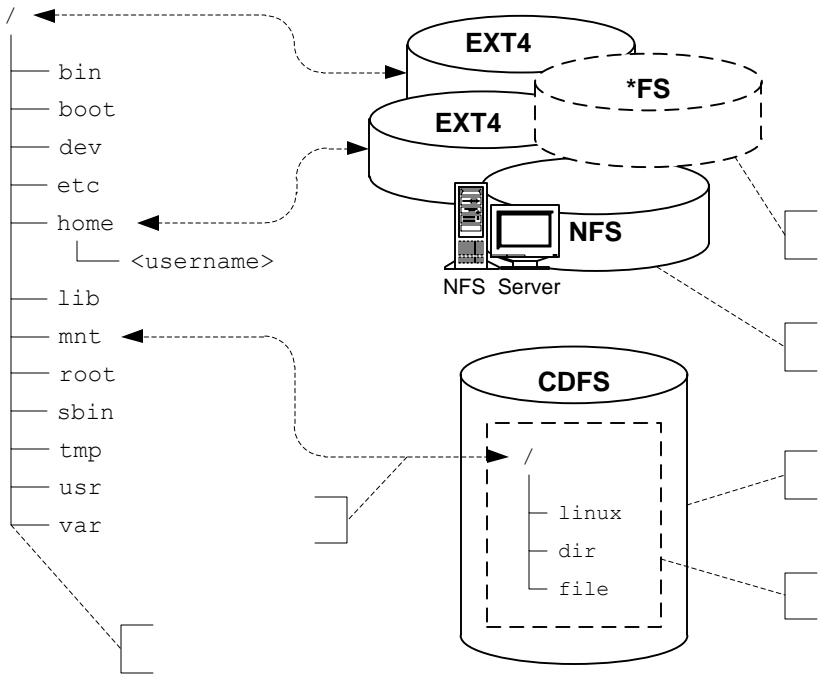

Рис. 4.1

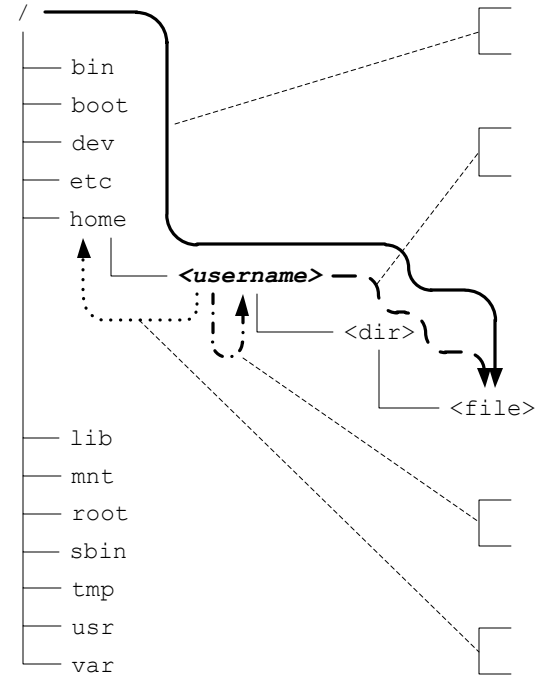

Рис. 4.2

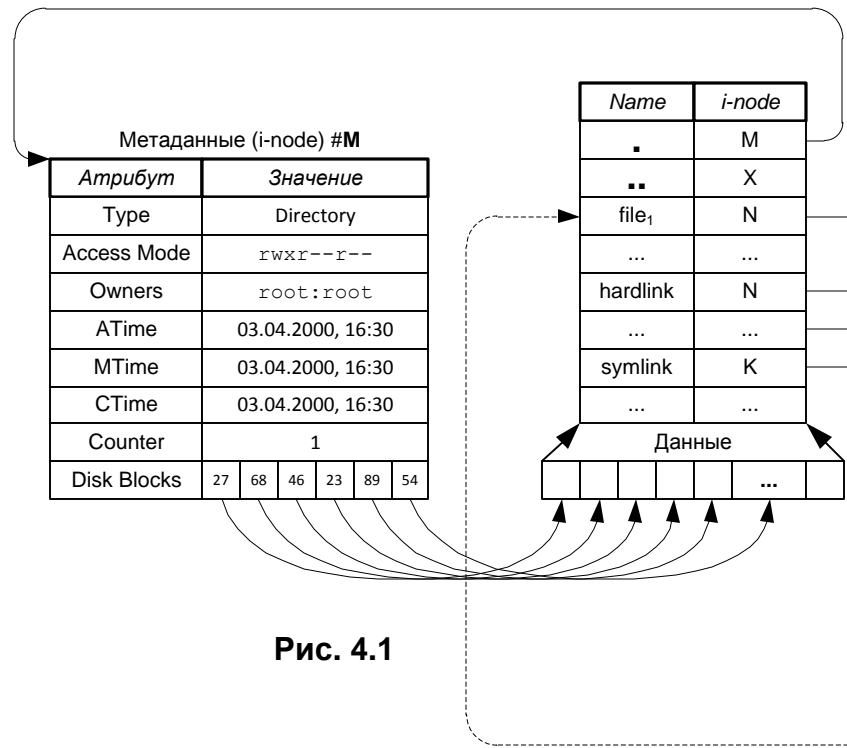

Рис. 4.3

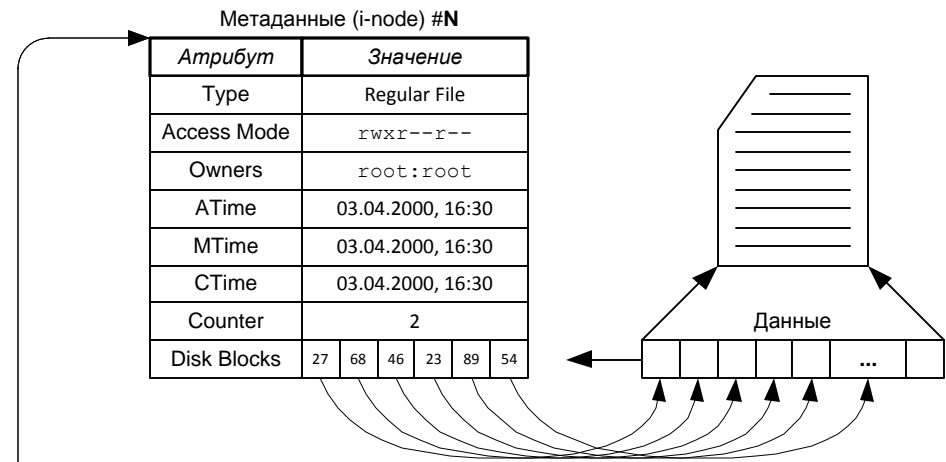

Рис. 4.5

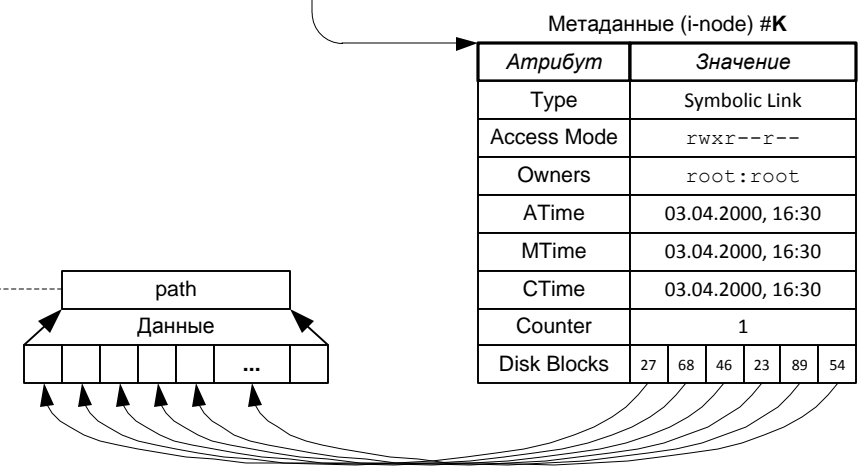

Рис. 4.4

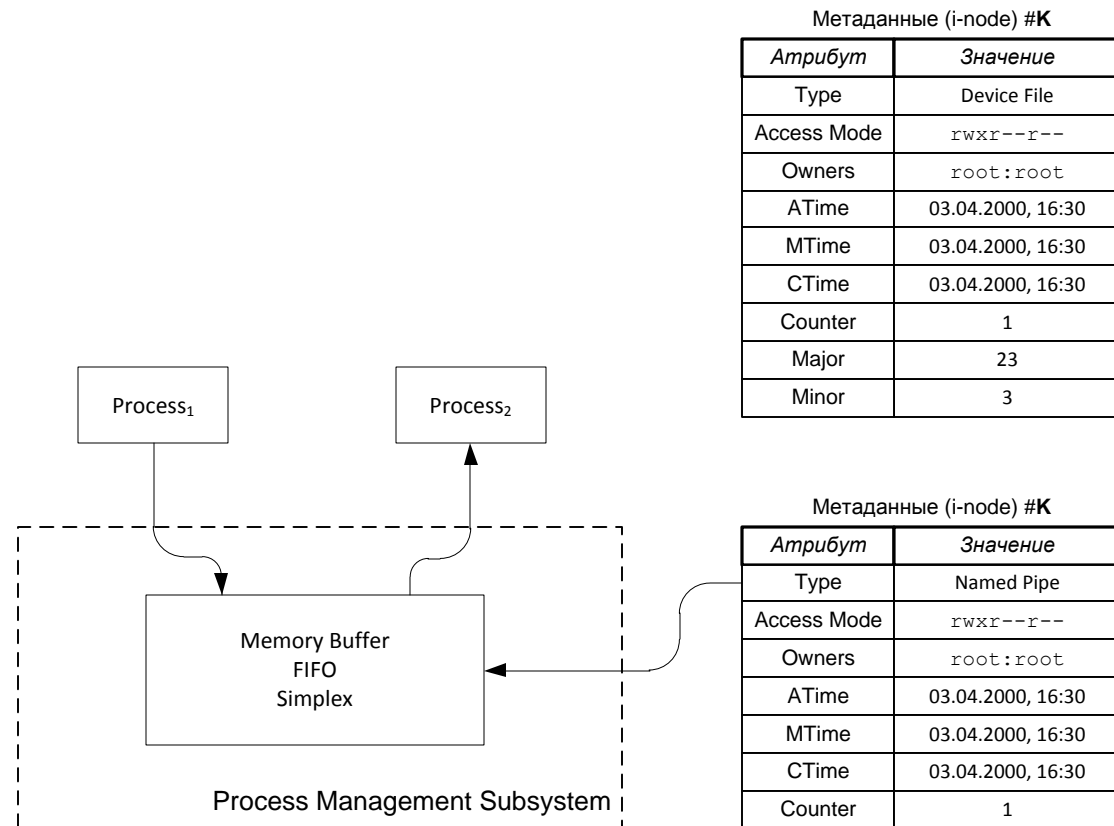

Рис. 4.6

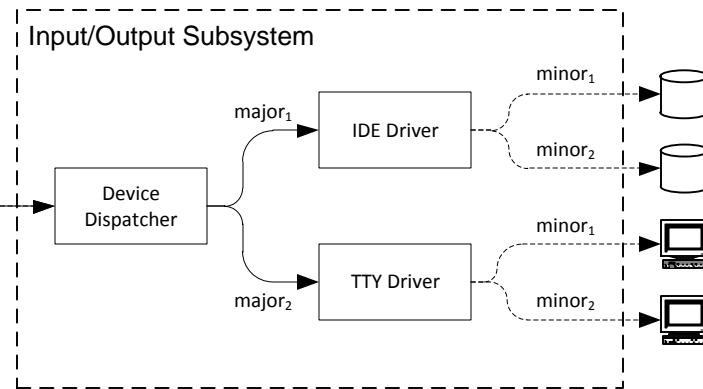

Рис. 4.7

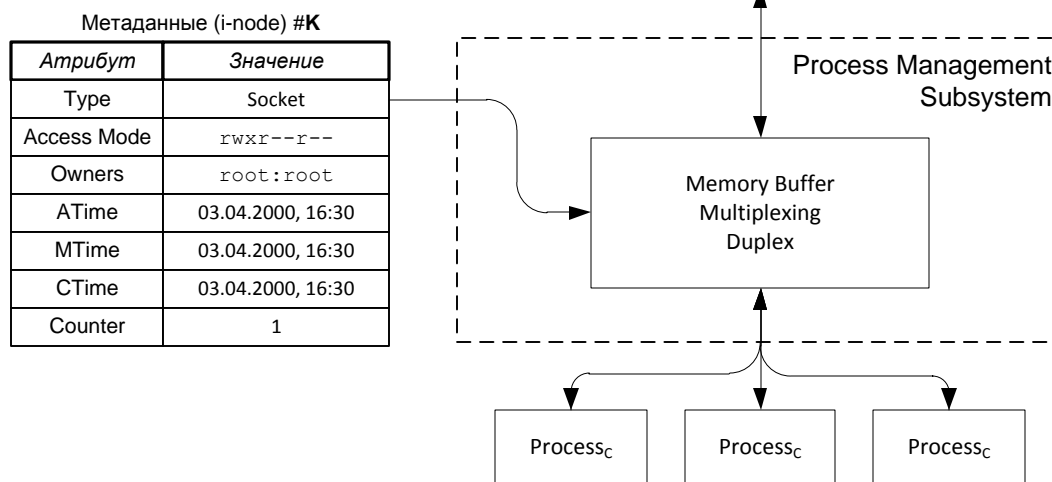

Рис. 4.8

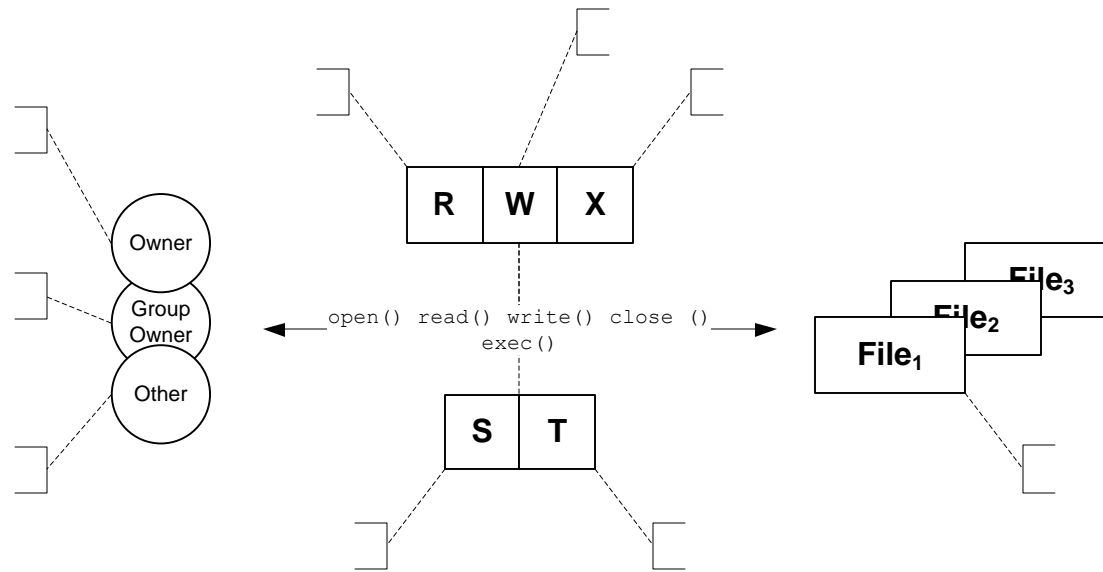

Рис. 4.9

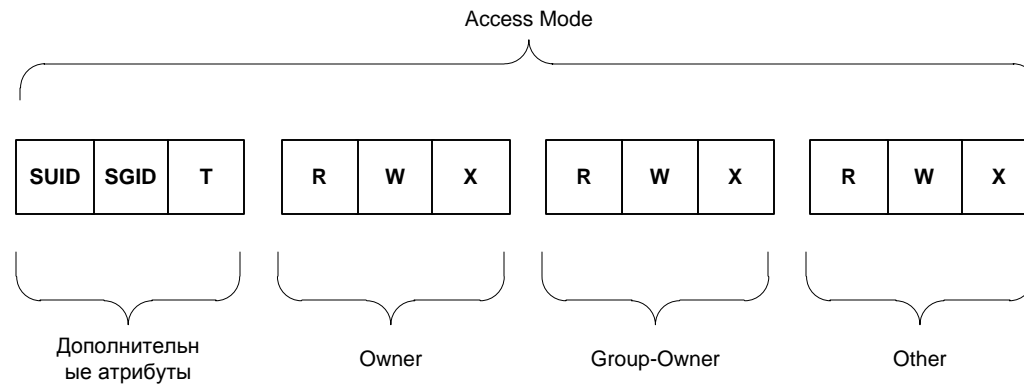

Рис. 5.1



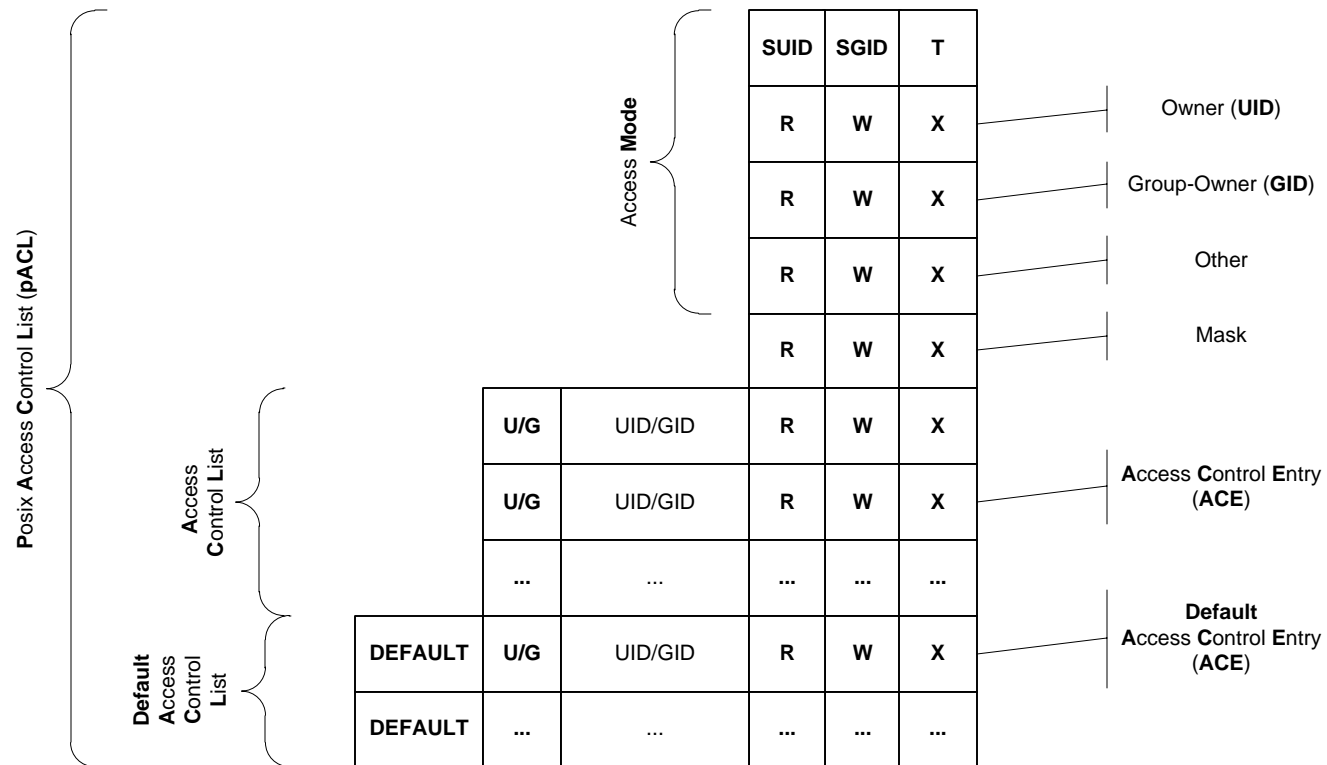

Рис. 5.2

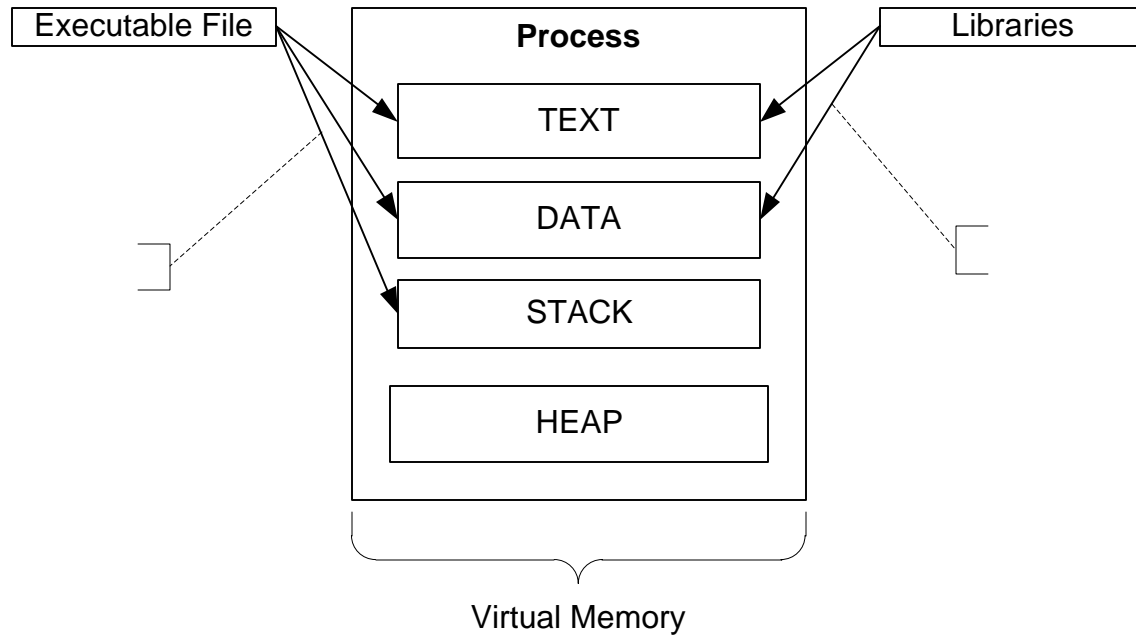

Рис. 5.3а

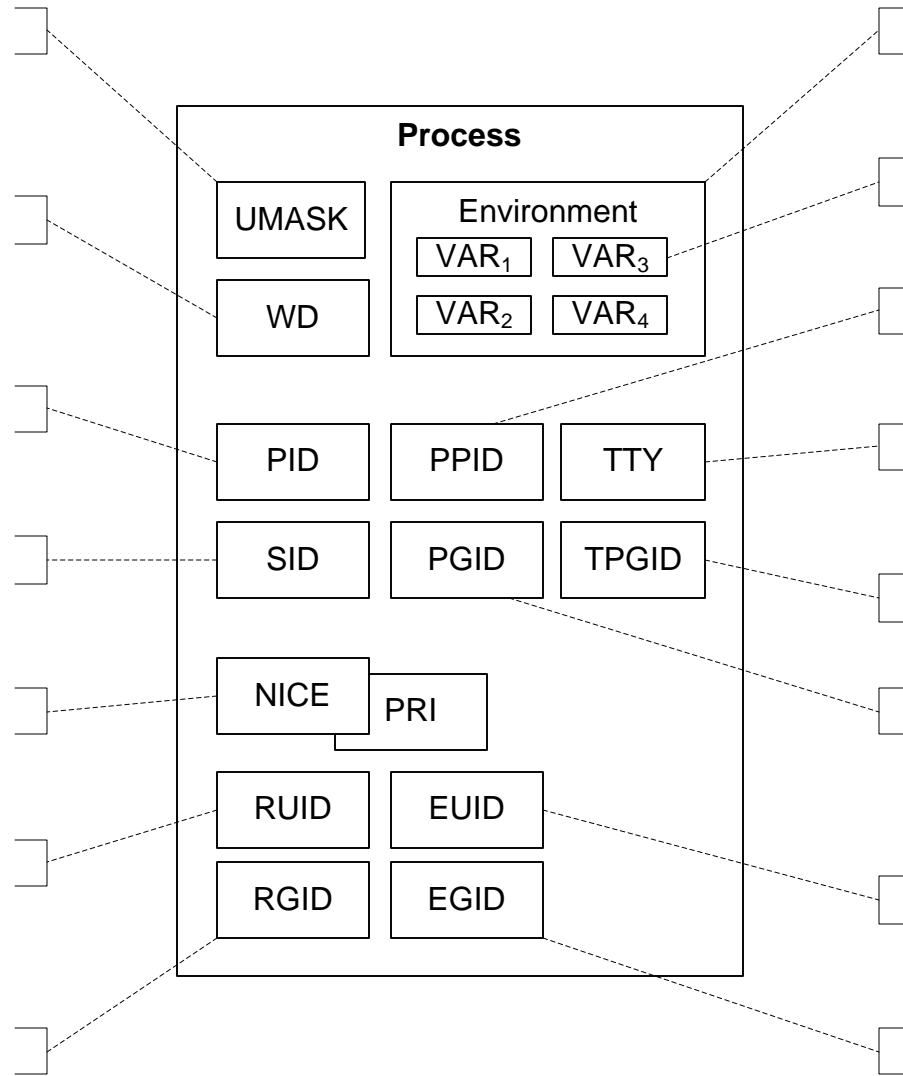

Рис. 5.3б

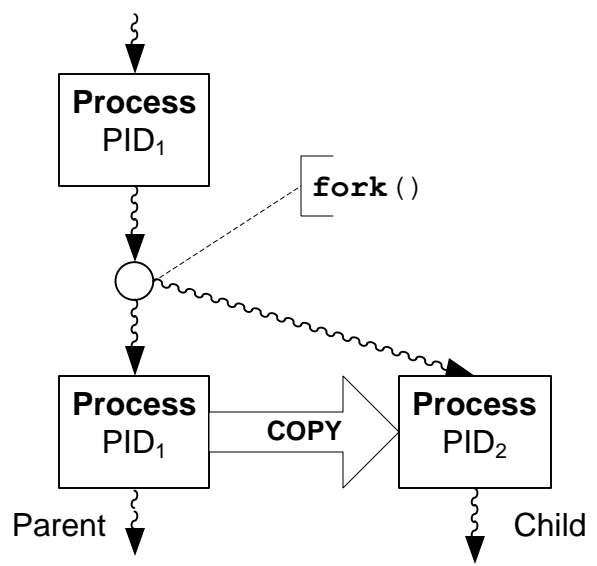

Рис. 5.3в

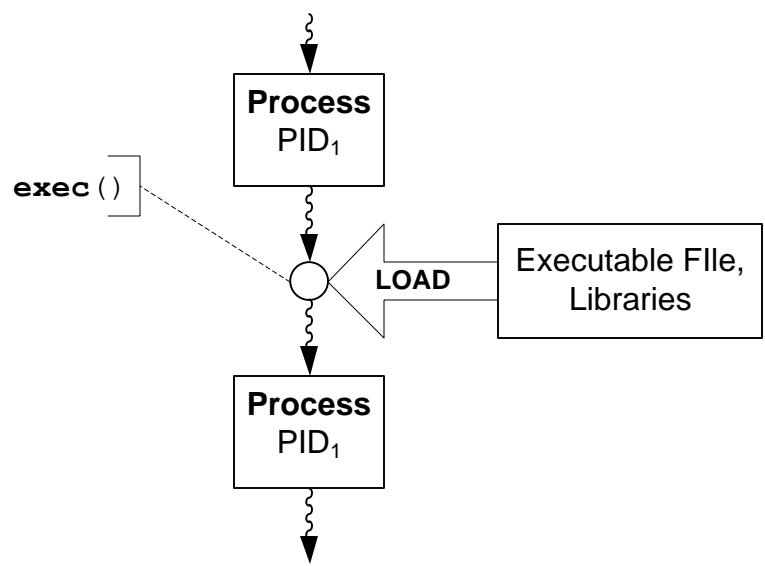

Рис. 5.3г

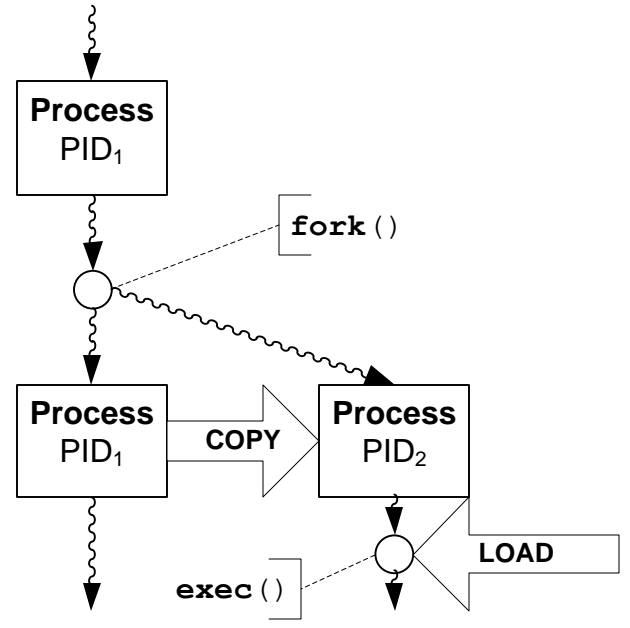

Рис. 5.4

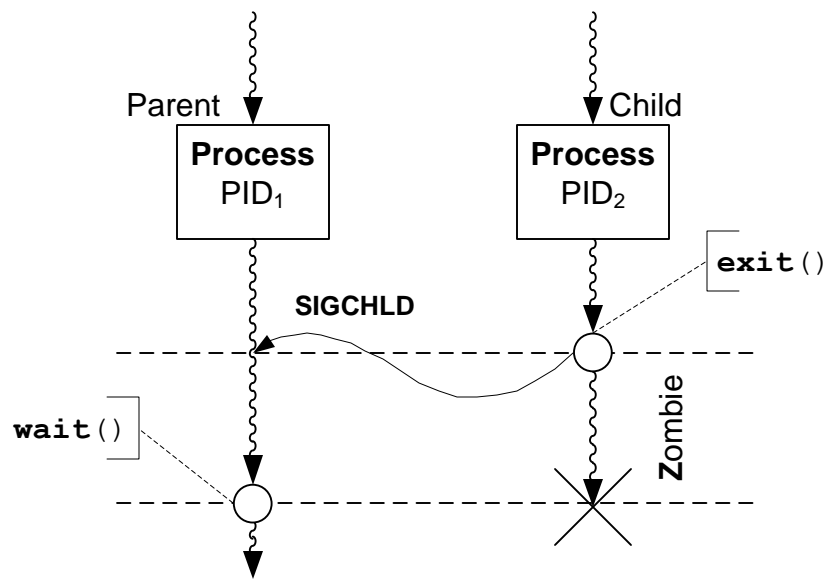

Рис. 5.5

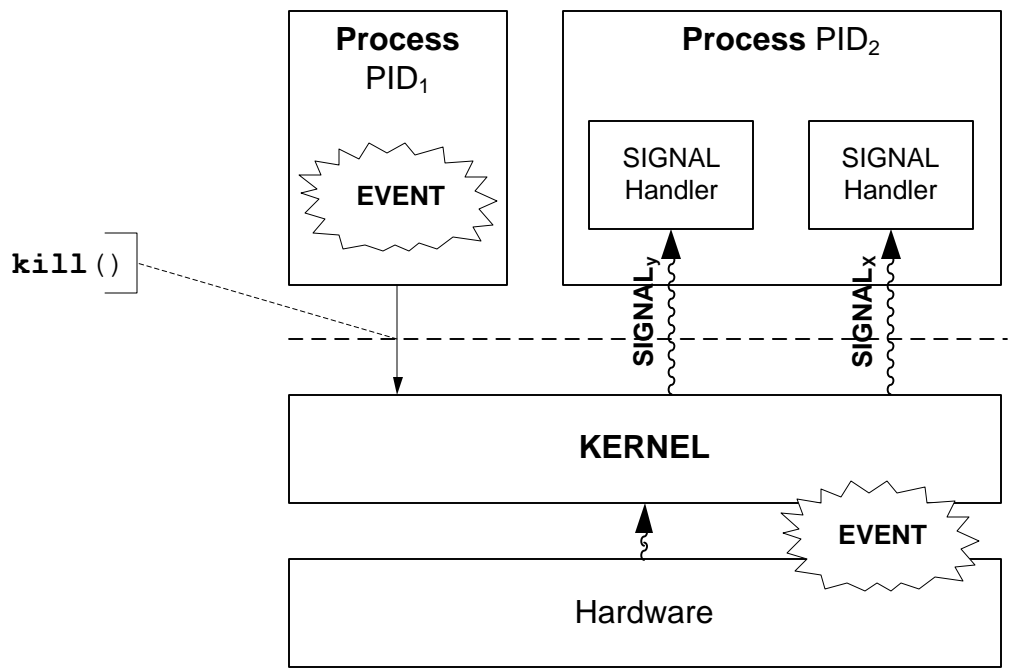

Рис. 5.6

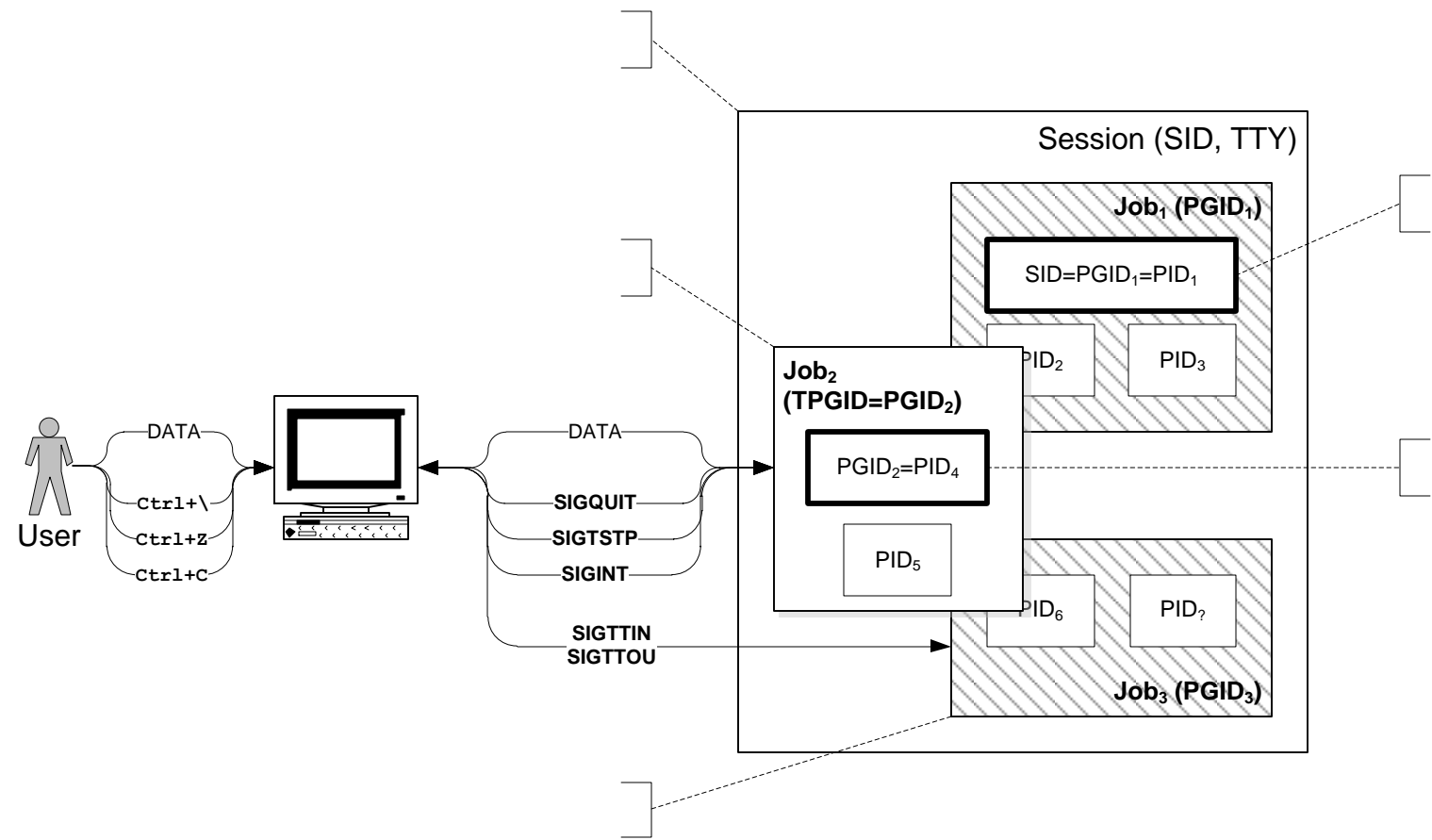

Рис. 6.1

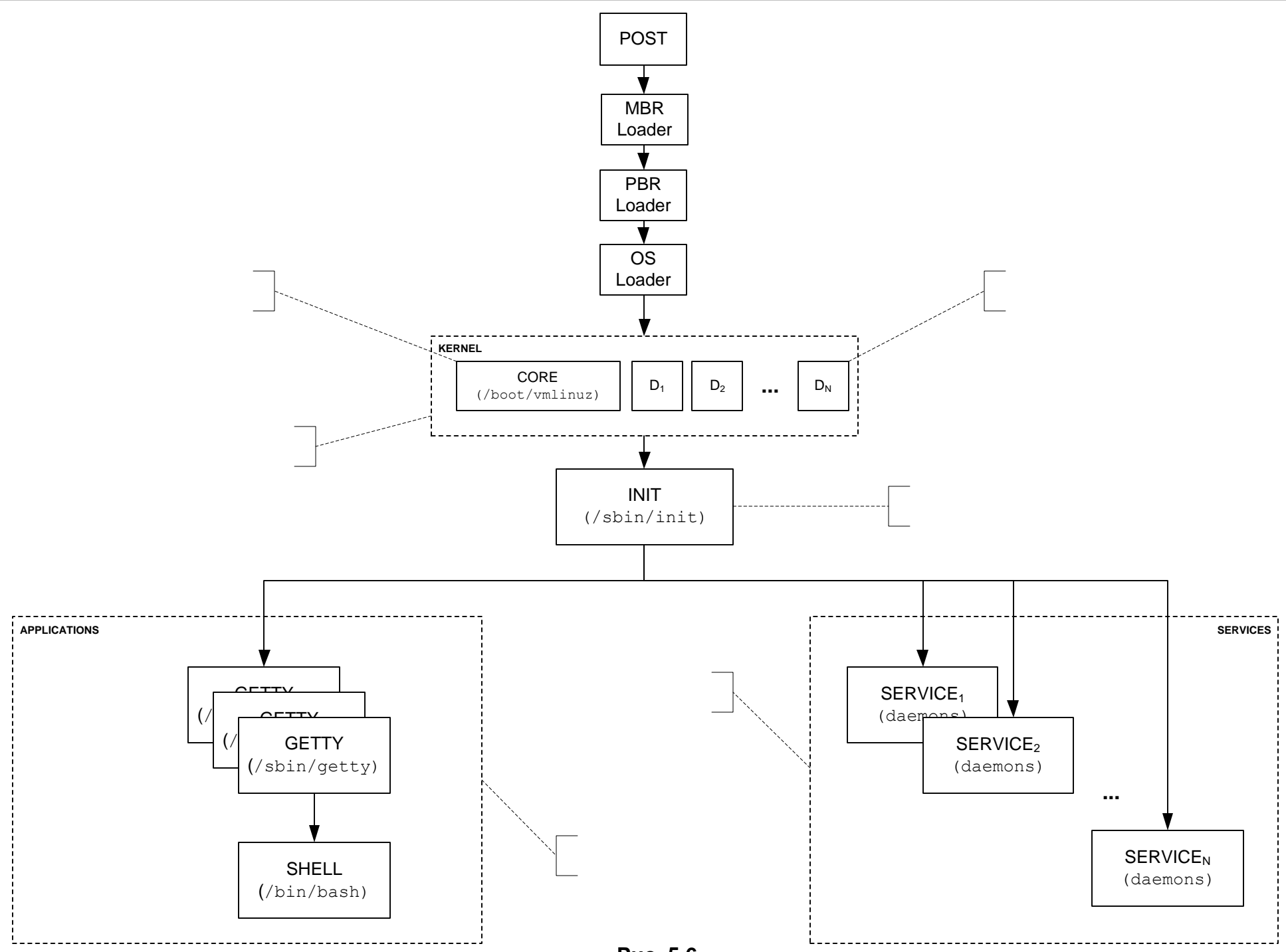

Рис. 6.2

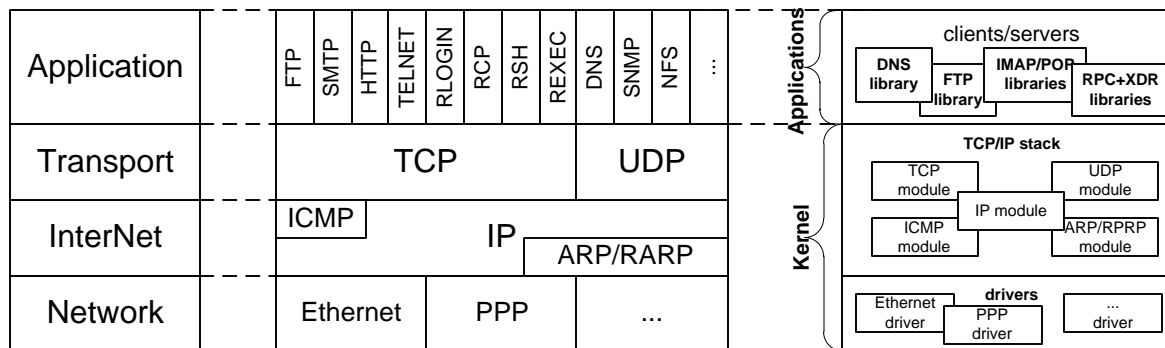

Рис. 6.3

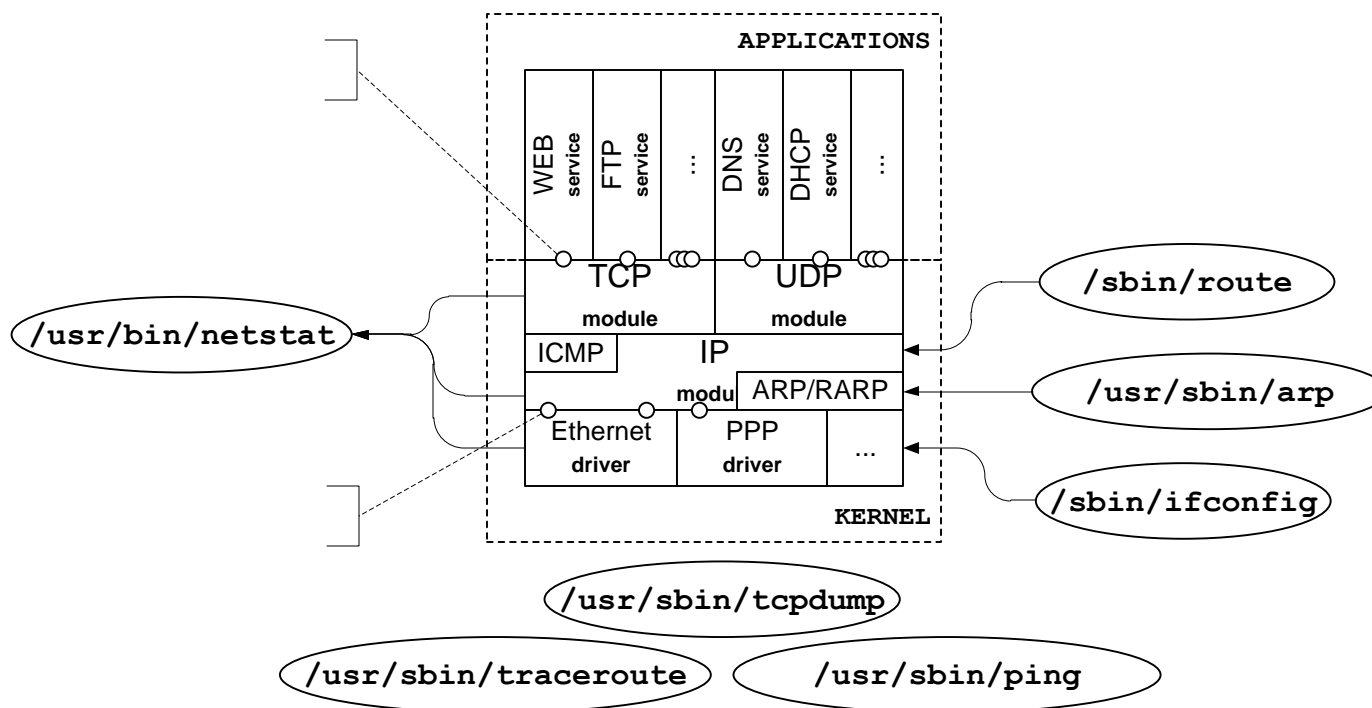

Рис. 6.4а

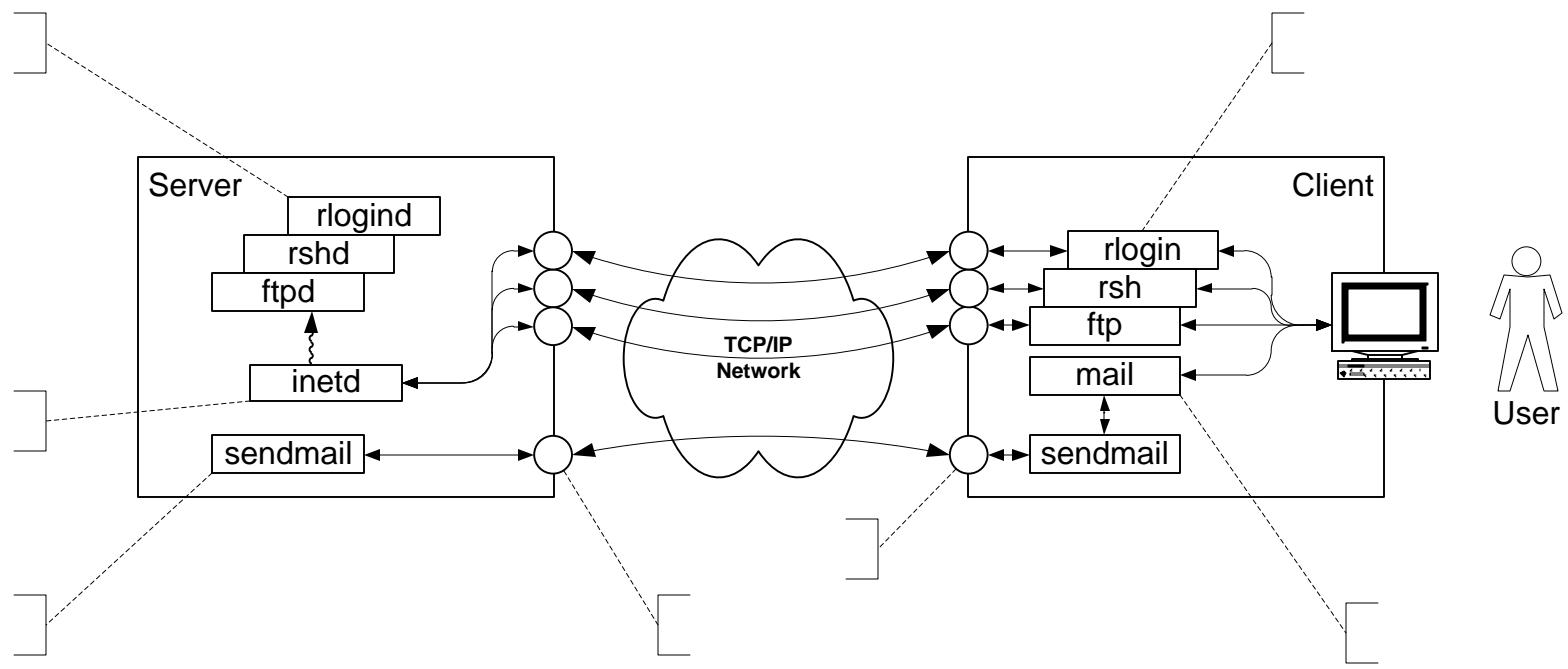

Рис. 6.4б



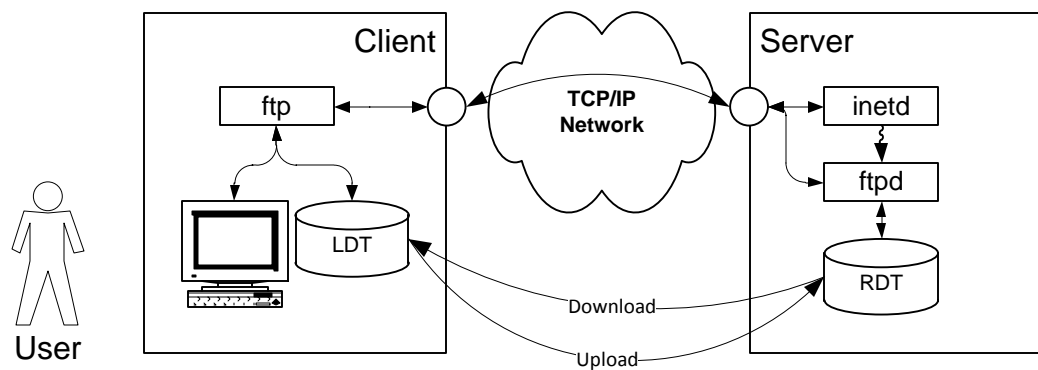

Рис. 6.5а

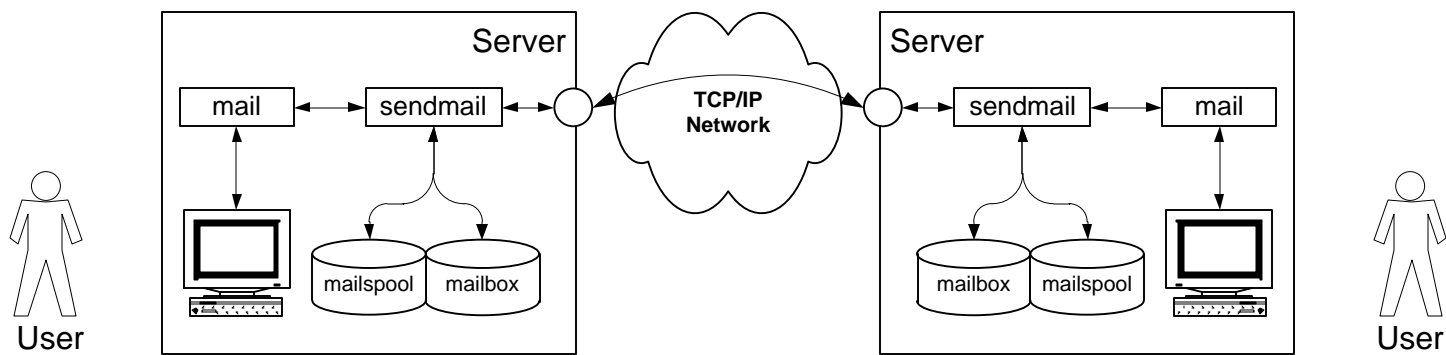

Рис. 6.5б

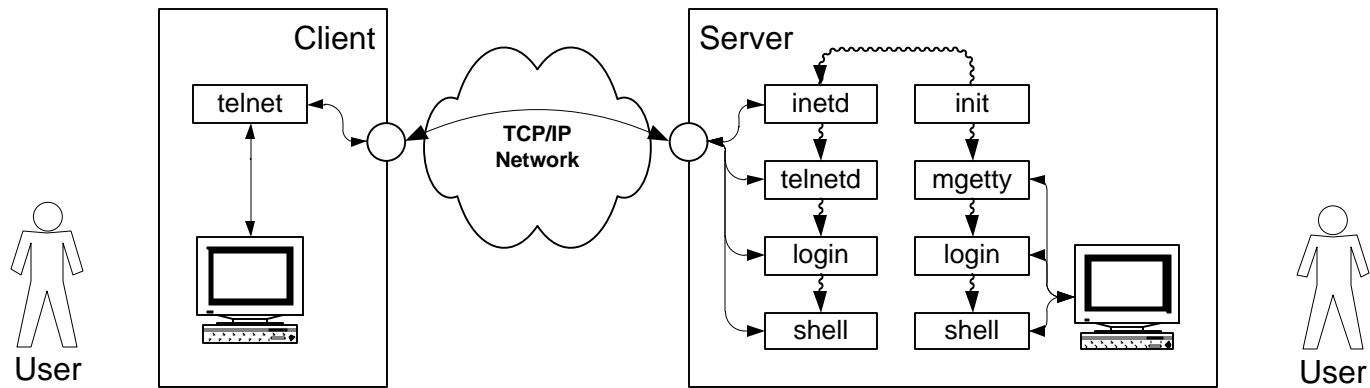

Рис. 6.5в

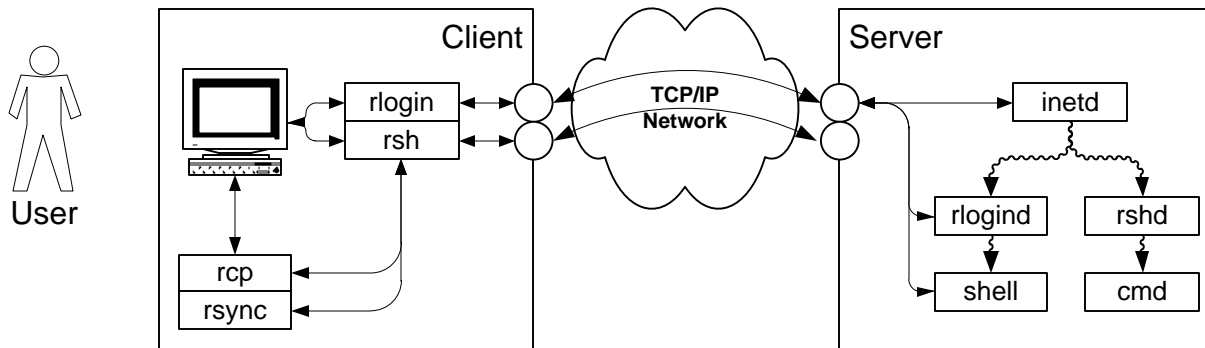
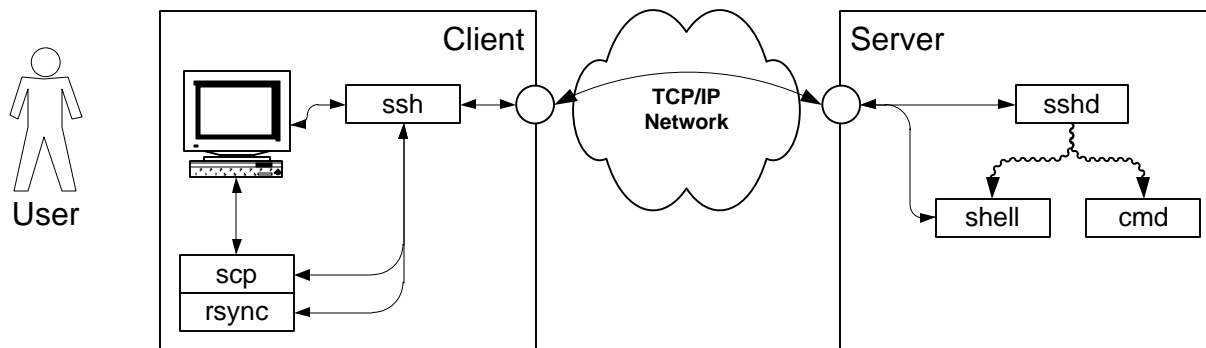
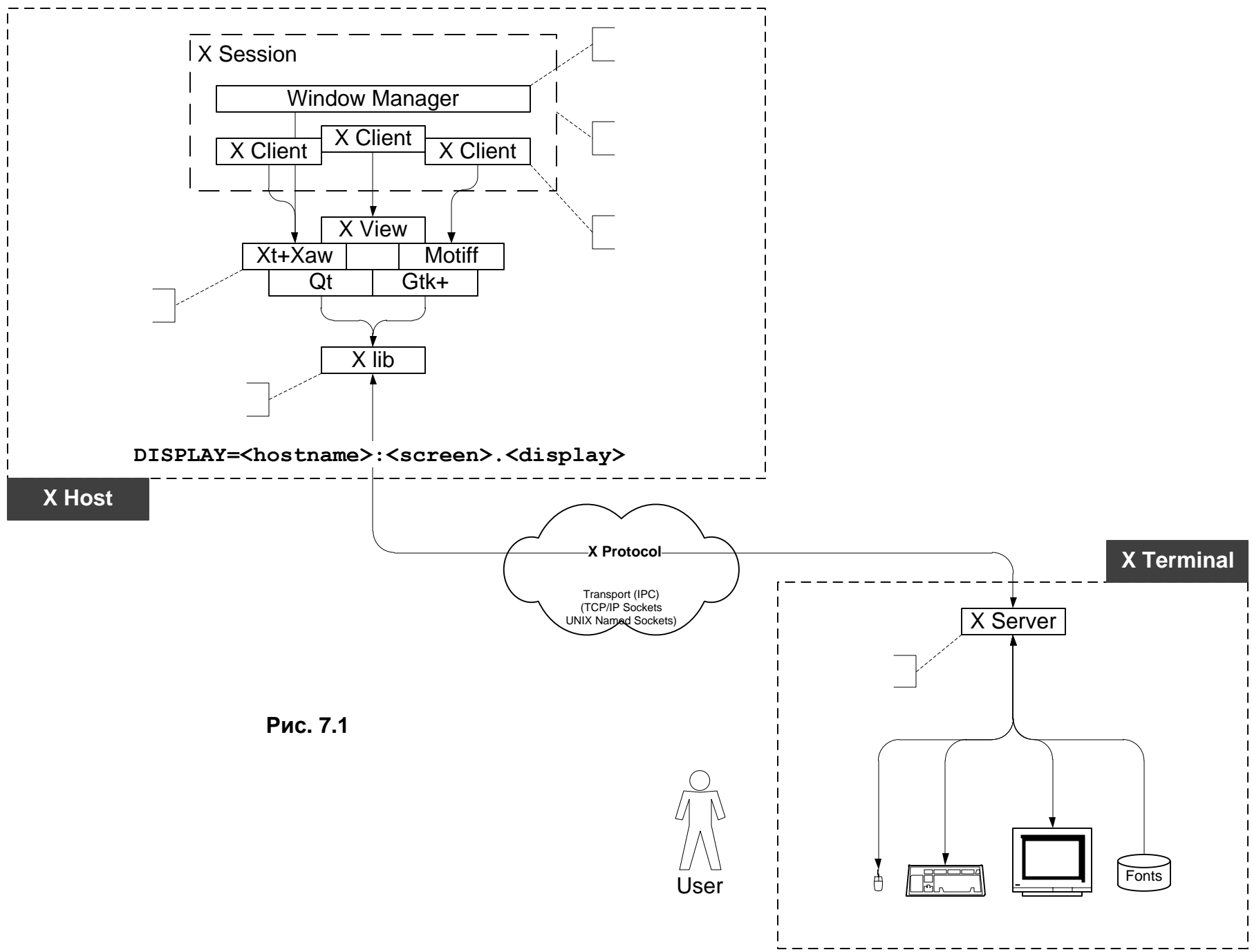

Рис. 7.1